

Kirikí

Embroidery Stitch Library

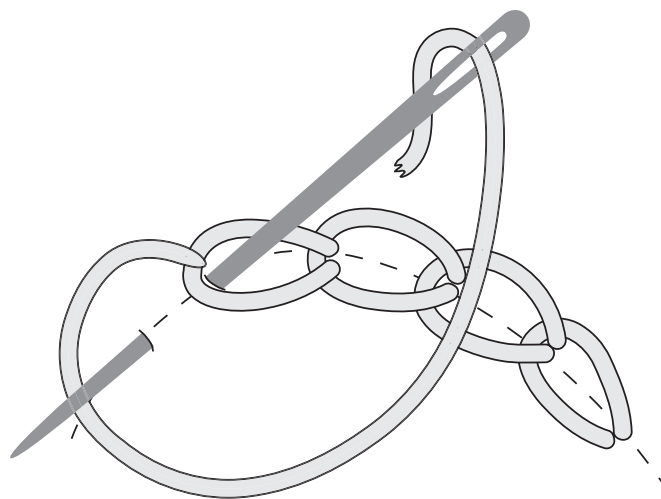

Michelle Galletta
Kirikí Press • Toronto • 2013

CONTENTS

The Basics.....	3
Getting Started.....	6
Straight Stitch/Seed Stitch.....	9
Fly Stitch.....	10
Feather Stitch.....	11
Fern Stitch.....	12
Chain Stitch.....	13
Buttonhole Stitch.....	14
Buttonhole Wheel & Scallops.....	15
Heavy Buttonhole Stitch.....	16
Split Stitch.....	17
Satin Stitch.....	18
French Knot.....	20
Arrowhead Stitch.....	21
Square Laid Work.....	22

This zine details all of the stitches used in **Kirikí D.I.Y. Embroidered Doll Kits**, along with some tips and tricks that will get you stitching beautiful dolls and any other project you'd like to embroider.

Hand embroidery is a craft that spans cultures and generations. It produces decorative and intricate stitches that are actually quite simple once you learn the techniques. Embroidery is a relaxing hobby so be patient as you learn how to stitch - practice really does make perfect - and always have fun. Don't be afraid to cut stitches out and start over when you need to.

EMBROIDERY HOOP

It's important to use a good quality hoop that won't cause the fabric to slip while working. Flimsy wooden hoops tend to do this and will require constant tightening and readjustments. If you're using the embroidery hoop from the **Starter Kit** you'll see that one side of the inner hoop reads *THIS SIDE UP*. Keep this hoop face up and place the fabric over top. Press outer hoop down over fabric and under the lip of inner hoop. Carefully pull the fabric taut without distorting the shape and tighten the nut until the fabric is even and tight.

EMBROIDERY FLOSS

The floss that comes with the **D.I.Y. Embroidered Doll Kits** is DMC brand, a high quality cotton floss made in France that comes in a vast range of vivid colours.

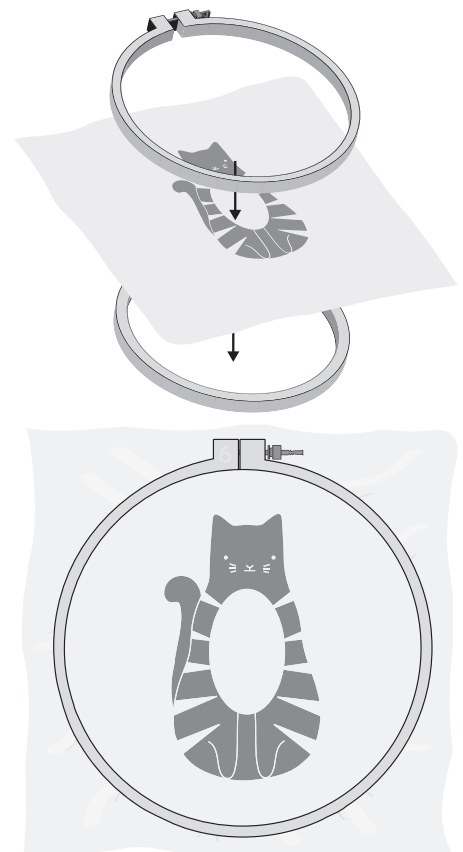

SEPARATING FLOSS

Most embroidery flosses, DMC included, are comprised of 6 easily separable strands that allow for various thicknesses of stitches by using a different number of strands. To separate the floss into individual strands, pull the number of strands you need until they are separate from the rest and smooth them out with your thumb and forefinger before threading them onto your needle.

CUTTING FLOSS

You don't want to use too much or too little thread. Use floss at about 14" in length. The longer your floss is, the more easily it will tangle. At the same time, you don't want your floss to be too short or else you will constantly have to re-thread your needle. A quick and easy way to measure an ideal length of thread is to pinch the end of the thread between your thumb and index finger, extend your arm and measure to the crease of your elbow.

TYING A KNOT

Before threading your needle make a knot on one end of your thread. Follow the diagram for quick and easy knots.

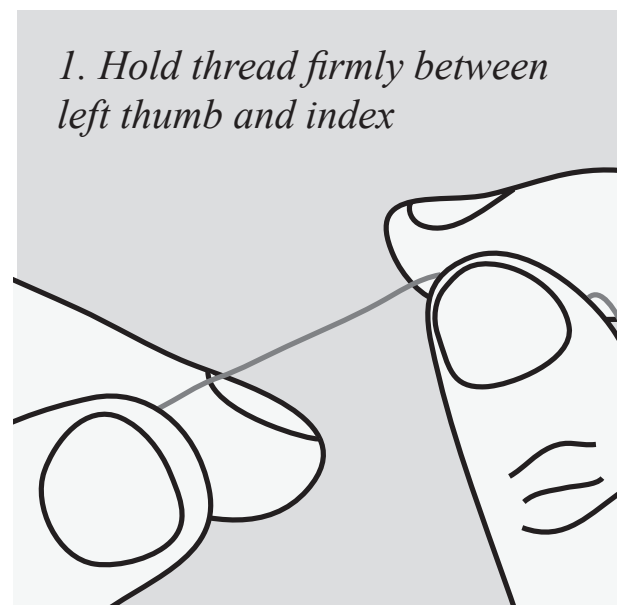

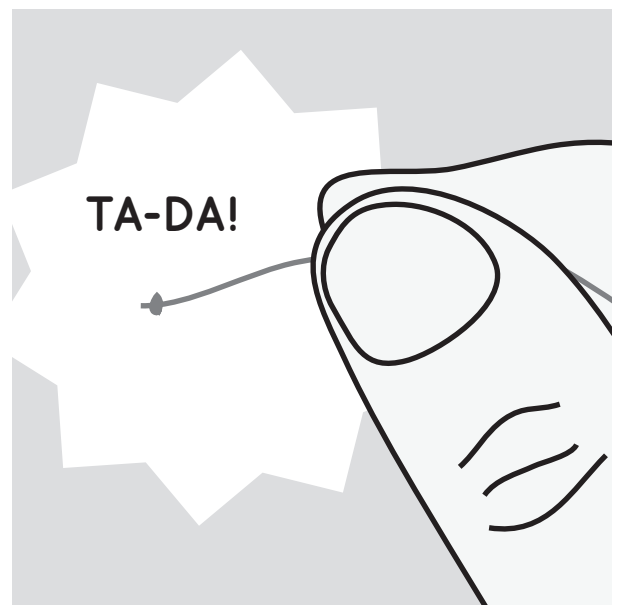
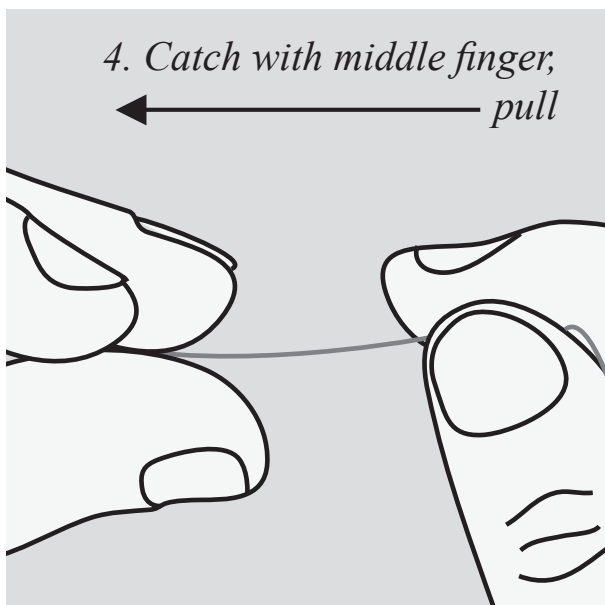
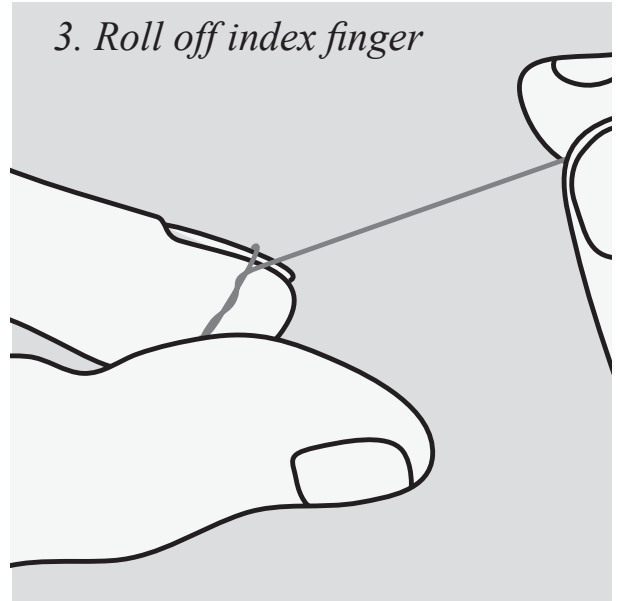
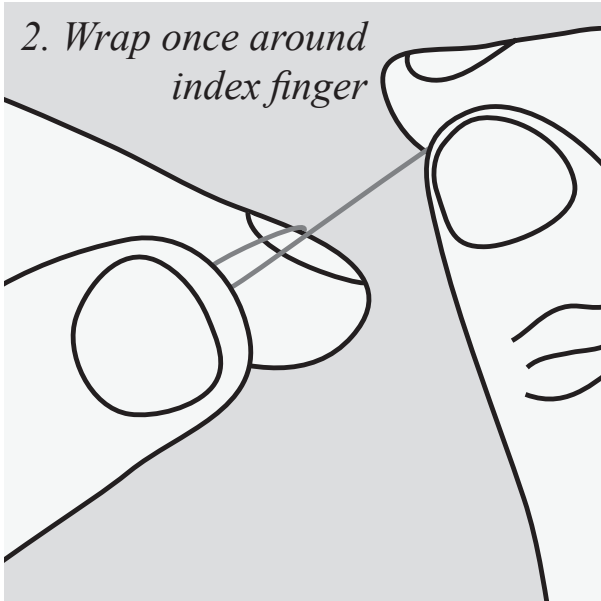

THREADING THE NEEDLE

The **Starter Kit** comes with two needles: a no. 10 to use with 1 strand of floss and a slightly larger no. 9 to use with 2-3 strands. Using a needle threader is the easiest way to thread a needle, but if you don't have one simply pinch the thread between your thumb and forefinger, leaving only a small tip exposed, and push through the eye. Leave a 3" to 4" tail hanging on one end.

I know it's tempting, but don't lick your thread! Saliva causes corrosion and the needle will eventually lose its smooth finish, making it more likely to catch on threads or the fabric.

STARTING A STITCH

The back of an embroidery is just as important as the front! A back side filled with knots and tangled threads makes it very difficult to produce neat and beautiful stitches. For this reason, I recommend starting and stopping stitches without leaving knots. There are several ways to achieve this:

Waste Knot

The Waste Knot works best when you are stitching a line and there are no previous stitches on which you can anchor your thread.

To begin, take the needle from the front to the back about 1" from your starting point, leaving a knot on the front side of

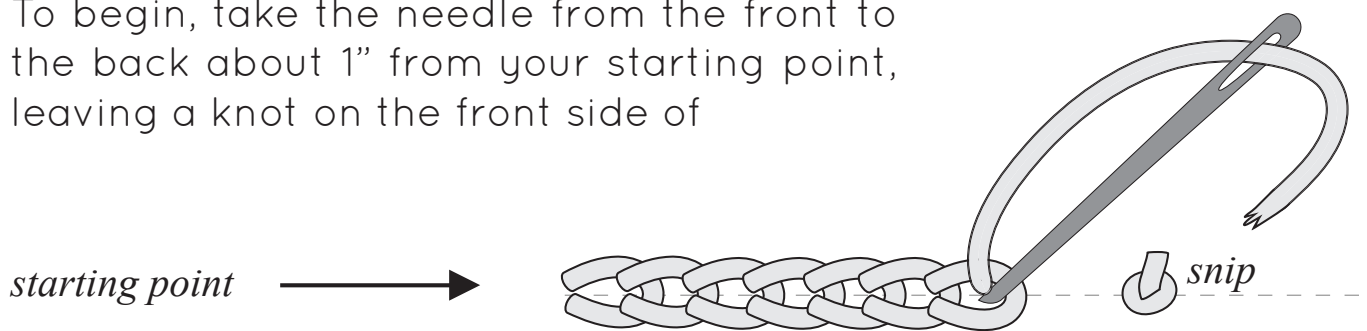

your fabric. Take the needle through the starting point and stitch towards the knot, ensuring that each stitch helps to secure the thread on the back. Snip the knot with scissors just before reaching it.

Away Knot

The Away Knot is a good choice when you are stitching detached stitches and there are no previous stitches on which to anchor your thread. To begin, take the needle a few inches from the starting point, leaving a knot on the front side of your fabric. When you finish stitching with your thread snip the knot. Turn over your hoop and re-thread the needle with the loose piece of thread, weaving it through stitches until it is securely in place.

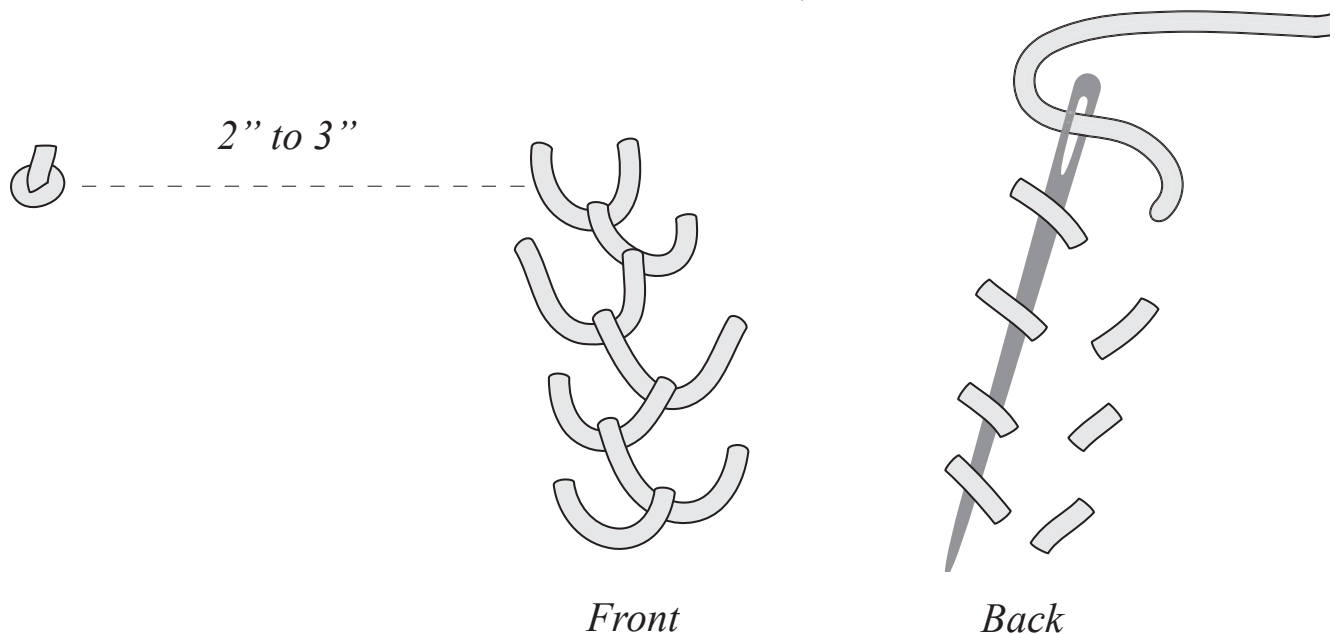

6 • *Getting Started*

Running Stitches

If you are stitching over areas that will be fully covered you can make a small series of Straight Stitches which will be embroidered over.

Knot & Weave

Once there are existing stitches on which to anchor new threads, you can commence a new stitch with a far shorter version of the Away Knot, placed 1/4" inch away from the existing stitches, close to your starting point. Weave into the back of these stitches and snip the knot away once the thread is secure. Begin your new stitch.

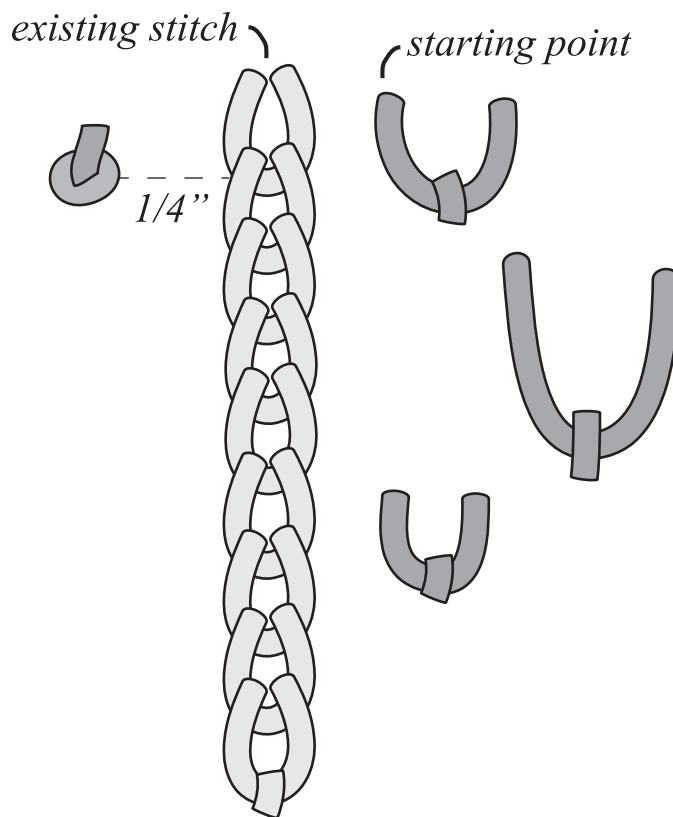

ENDING A THREAD

When you are getting close to the end of your thread leave enough so that it is easy to secure by weaving through several stitches on the back side of the embroidery. If you are halfway through a stitch do not attempt to tie on a new thread and continue stitching. Treat it as a finished stitch and commence anew with a new thread using one of the methods described in the previous section.

Straight Stitch • 9

The Straight Stitch is made of single, isolated stitches. They can be worked in a straight line, fill in a shape, or overlap each other. Tiny Straight Stitches that run in different direction to fill an area are known as Seed Stitches.

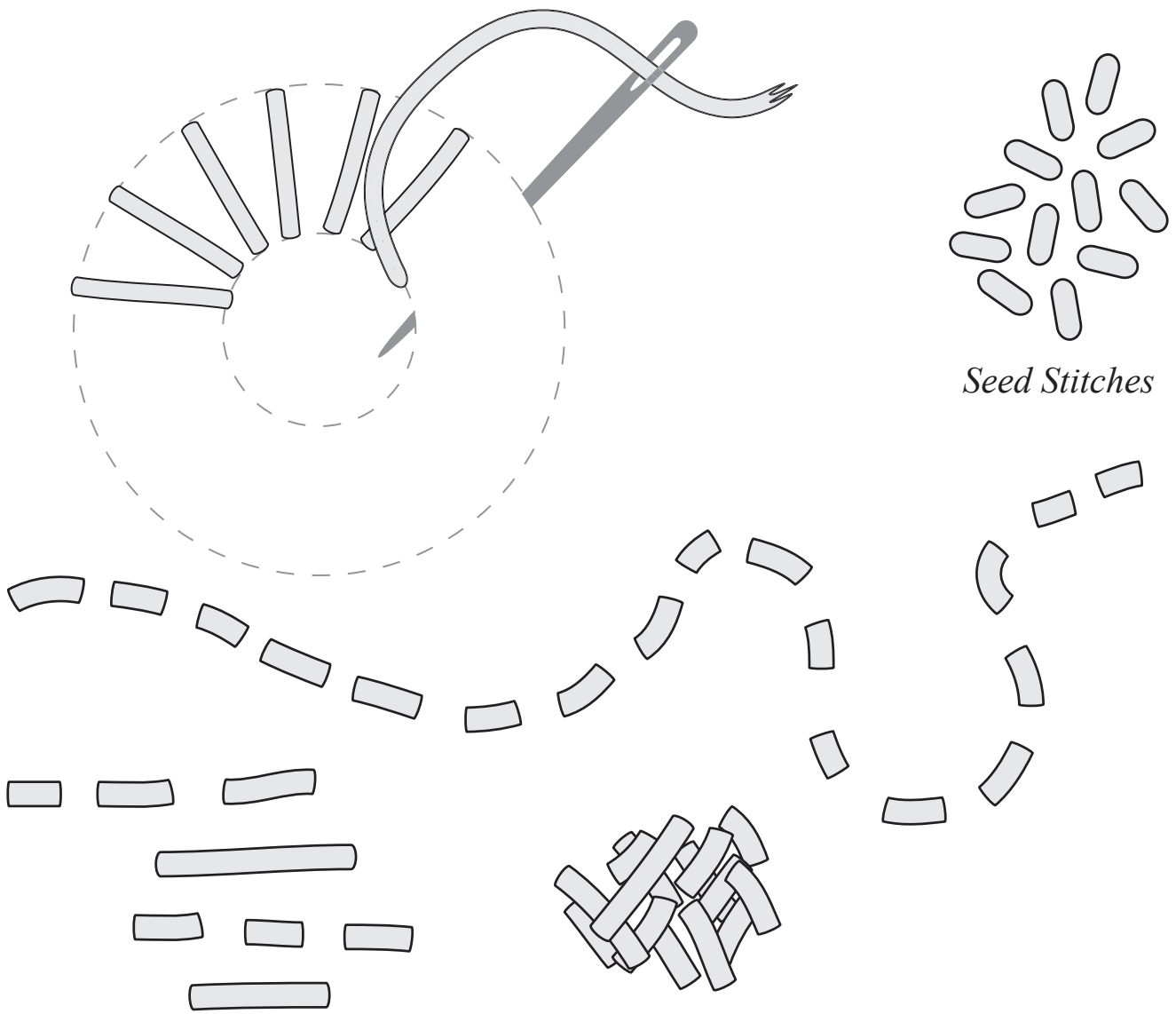

Bring the needle through the top left at (a). Catch the thread with your thumb and insert the needle to the right (b) at the same height, a short distance away. Keeping some slack in the working thread - like a “U” hanging between (a) and (b) - take a small stitch downwards and to the centre (c) and keeping the working thread below the needle, pull through and insert the needle below the thread to anchor it (d). Varying the distance between (c) and (d) will result in a longer or shorter tail (a “Y” look versus a “V” look). Repeat in the next location.

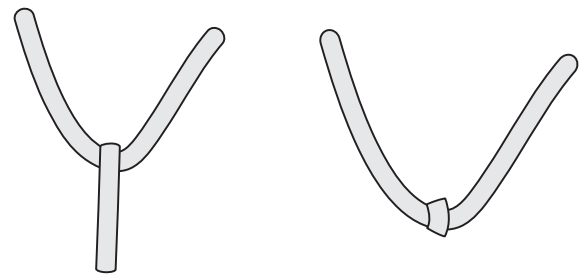
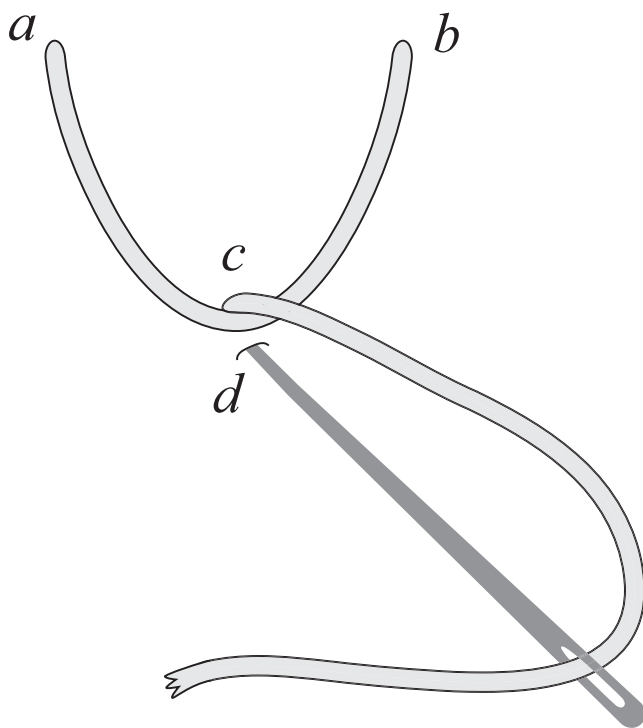

Detached Fly Stitch

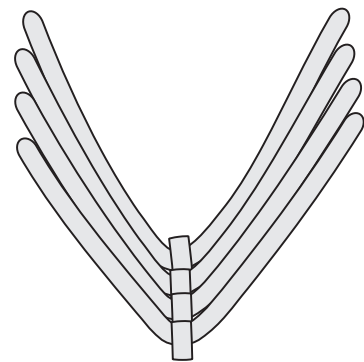

Closed Fly Stitch

Follow the directions for the Fly Stitch, but instead of anchoring the stitch, move (d) to the right/left and continue catching the working thread in this manner as you move down the line.

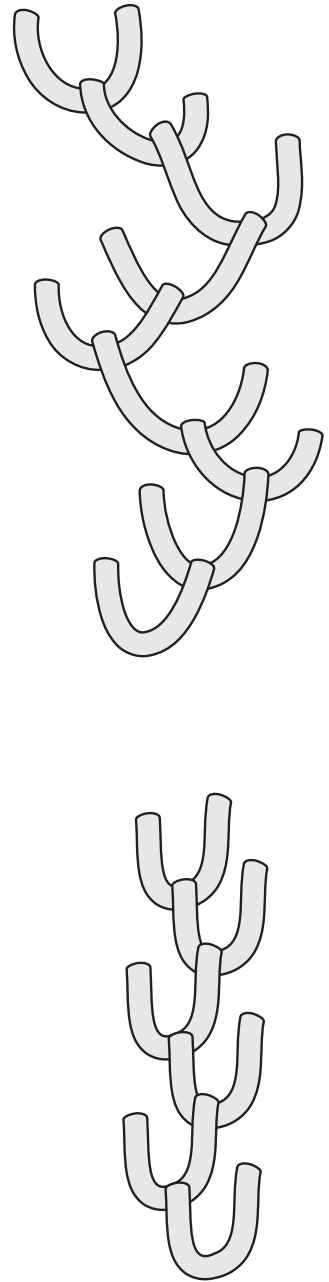
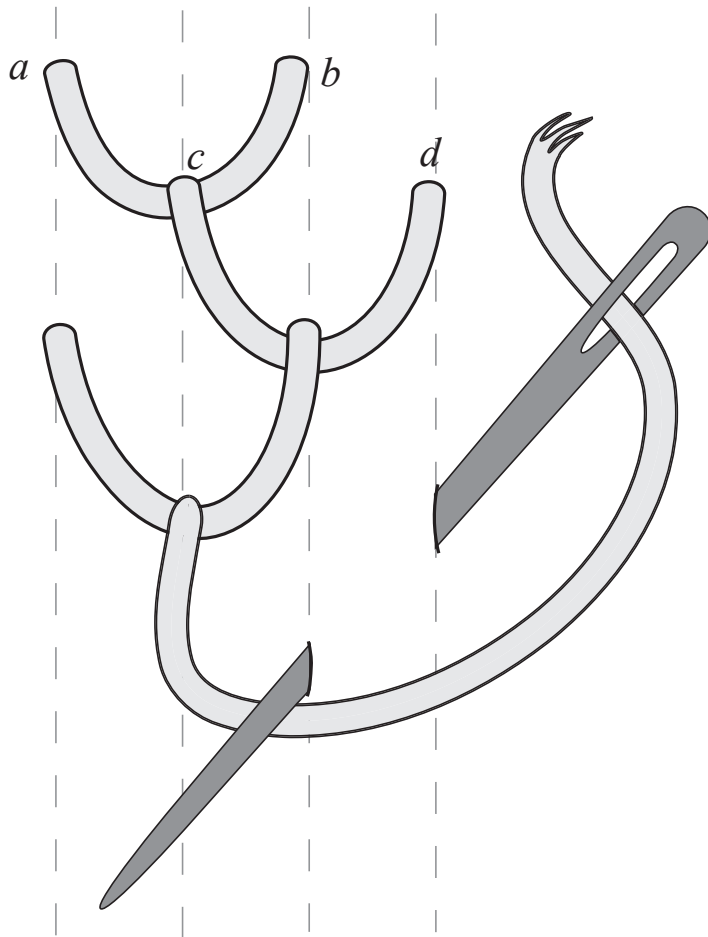

Fern Stitch • 12

The Fern Stitch is a simple stitch comprised of three straight stitches that radiate from a central point. To begin, make a straight stitch from bottom (a) to top (b). Exit to the left (c) and re-insert your needle at (a). Exit to the right (d) and re-insert your needle at (a). Repeat until your line is complete or move to the next location if you are making a series of Detached Fern Stitches.

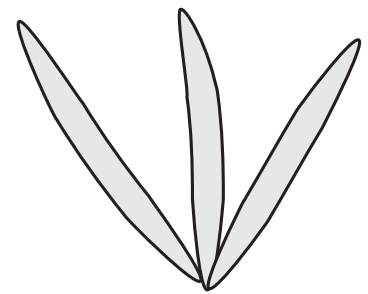
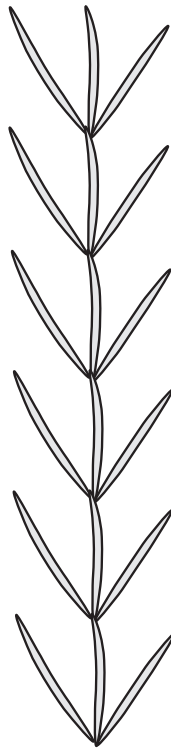
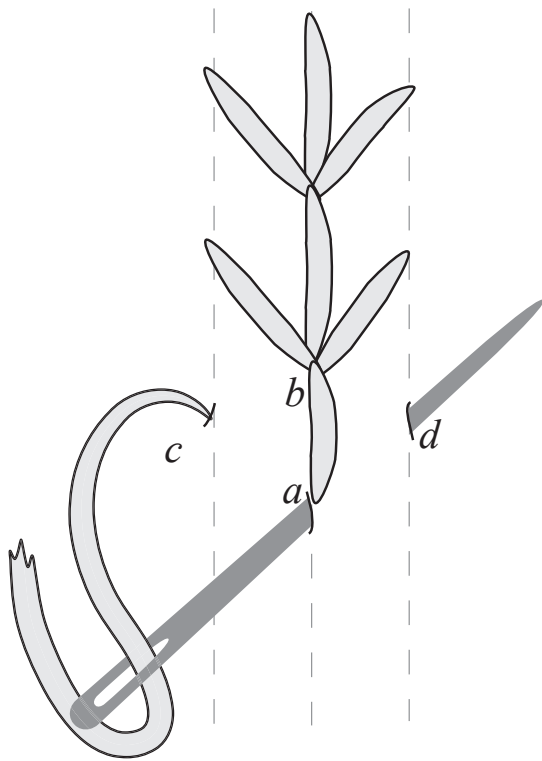

Detached Fern Stitch

The Chain Stitch is great for lines and curves. It's very versatile, creating not only detailed outlines, but dense fills that have a beautiful texture.

To make this stitch, bring the thread through the fabric and hold down with your left thumb. Go back through the same hole, still holding down the thread, and bring the needle back through a short distance away (1/8" or less). Once the needle is through the loop you can remove your thumb and give a light tug to tighten up the chain. Repeat.

Shorten the distance between chain "links" when going around curves for an even smoother line.

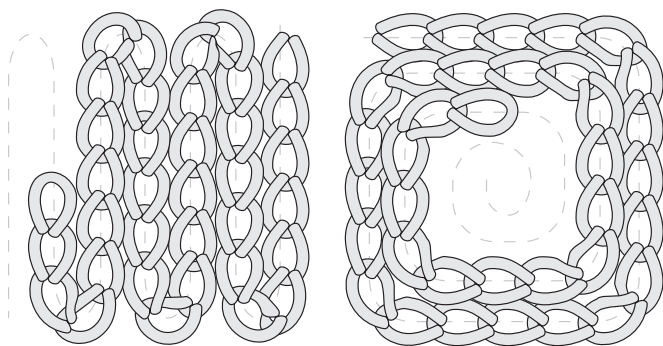
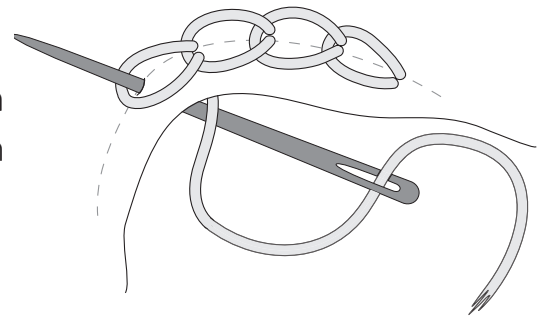
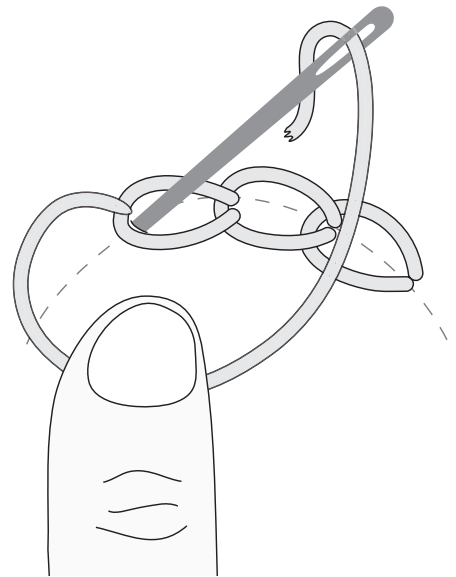

Chain Stitch fill

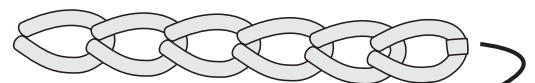

anchor with a single stitch

Buttonhole Stitch • 14

The Buttonhole Stitch (a.k.a. Blanket Stitch) creates a rope-like effect that's ideal for finishing edges of a design (you see this stitch on the edges of fleece blankets). Worked as a wheel or in scallops, it is a beautiful decorative stitch. Stitches can be made very close together or spaced out.

Bring the thread out on the lower line at (a). Insert the needle on the upper line one space to the right at (b). Catch the thread with your thumb and take a straight downward stitch to (c), ensuring that the working thread is under the needle. Repeat.

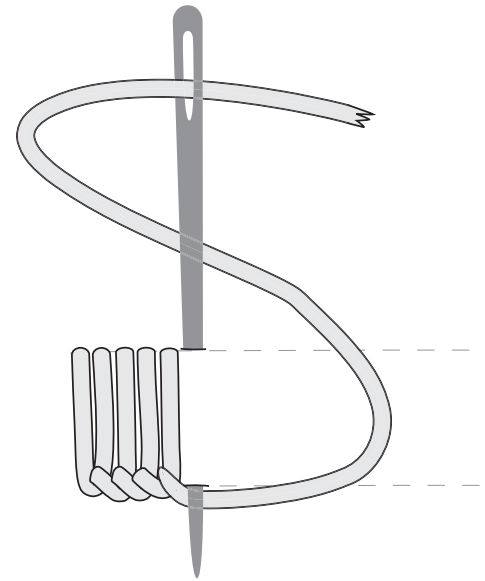
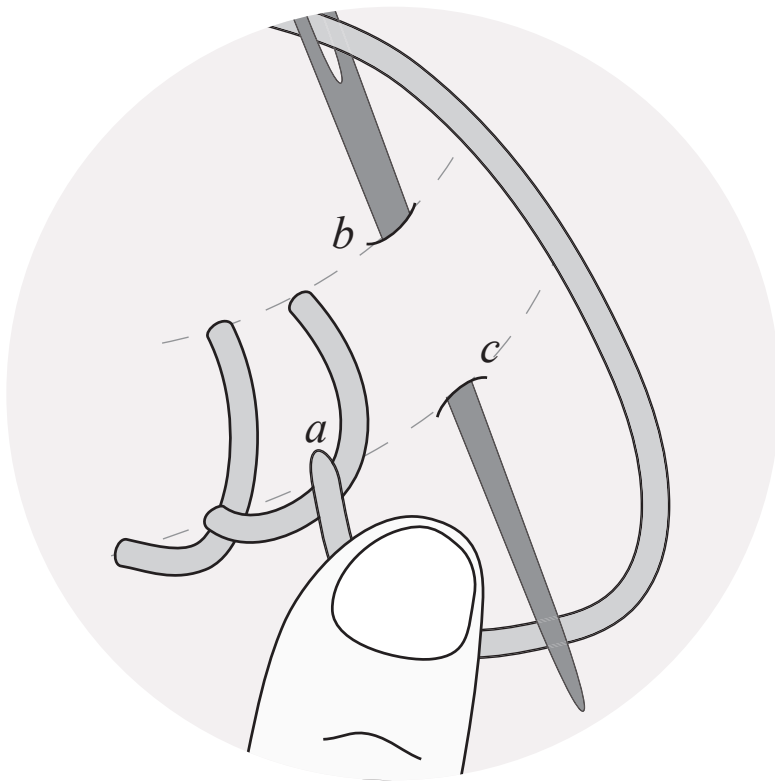

Buttonhole Wheel & Scallops • 15

Follow the same directions as the Buttonhole Stitch but use the outer edge of the circle as your “lower line” and a single point in the centre as the “upper line”

Buttonhole Scallops can either be worked like a Buttonhole Wheel, forming a semi-circle or quarter circle (B), or with vertical stitches that follow a shape (A).

Work rows of scallops from bottom to top.

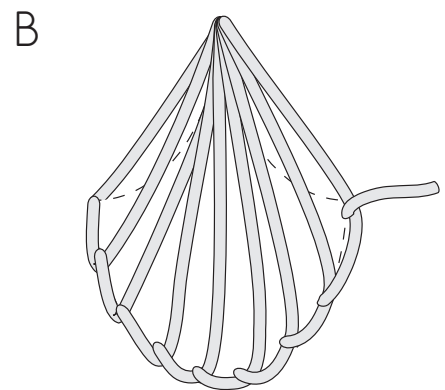
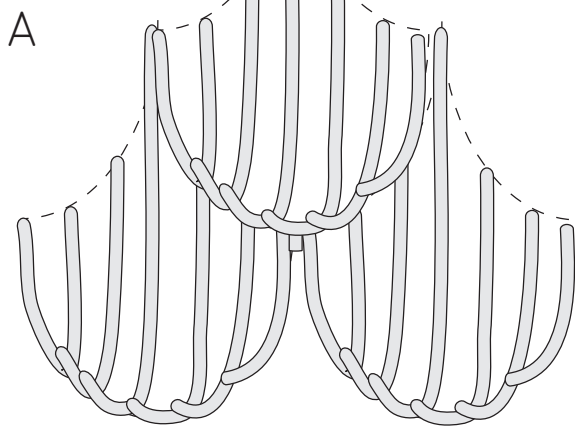
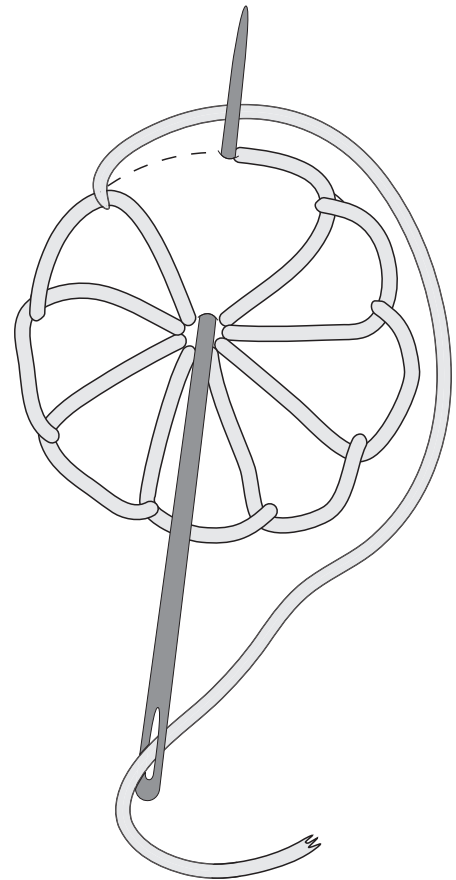

Heavy Buttonhole Stitch • 16

Once a Buttonhole Stitch is complete you can add a layer to emphasize the edge.

This is an example of a detached fill, where you build upon an existing stitch without going back into the fabric. The beginning and ending of this stitch are the only times that you pierce through the fabric.

Working in the same direction as the buttonhole stitch, come all the way up with your needle on the same hole where the buttonhole stitch was anchored. Keep the working thread below the stitch, and slide the needle under the thread of the first buttonhole segment, (not piercing any fabric), and over the working thread to create a loop. Give a light tug to tighten. Repeat through the next segment.

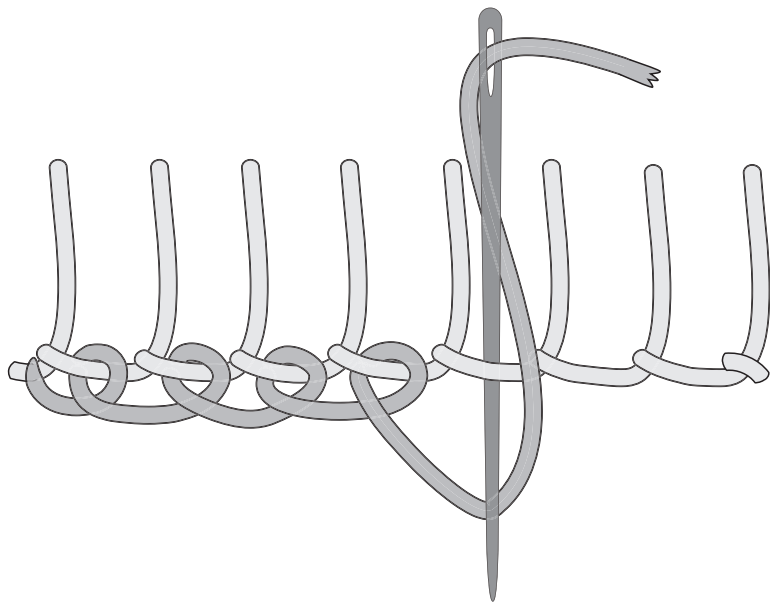

Repeat through the next segment. When you reach the end of the row pierce through the fabric and weave through stitches on the back side to secure in place.

When applied to a Buttonhole Wheel, it is known as a *Buttonhole Wheel Cup*, for the way it builds up around the wheel.

Split Stitch • 17

The Split Stitch is used for thin outlines and as padding underneath a Satin Stitch. Make a straight stitch along your line from (a) to (b). Bring the needle back through at (c), which is slightly closer to (b) than to (a). This will split the thread in half as the needle pulls through. Repeat until you come to the end of your line, finishing with a normal straight stitch.

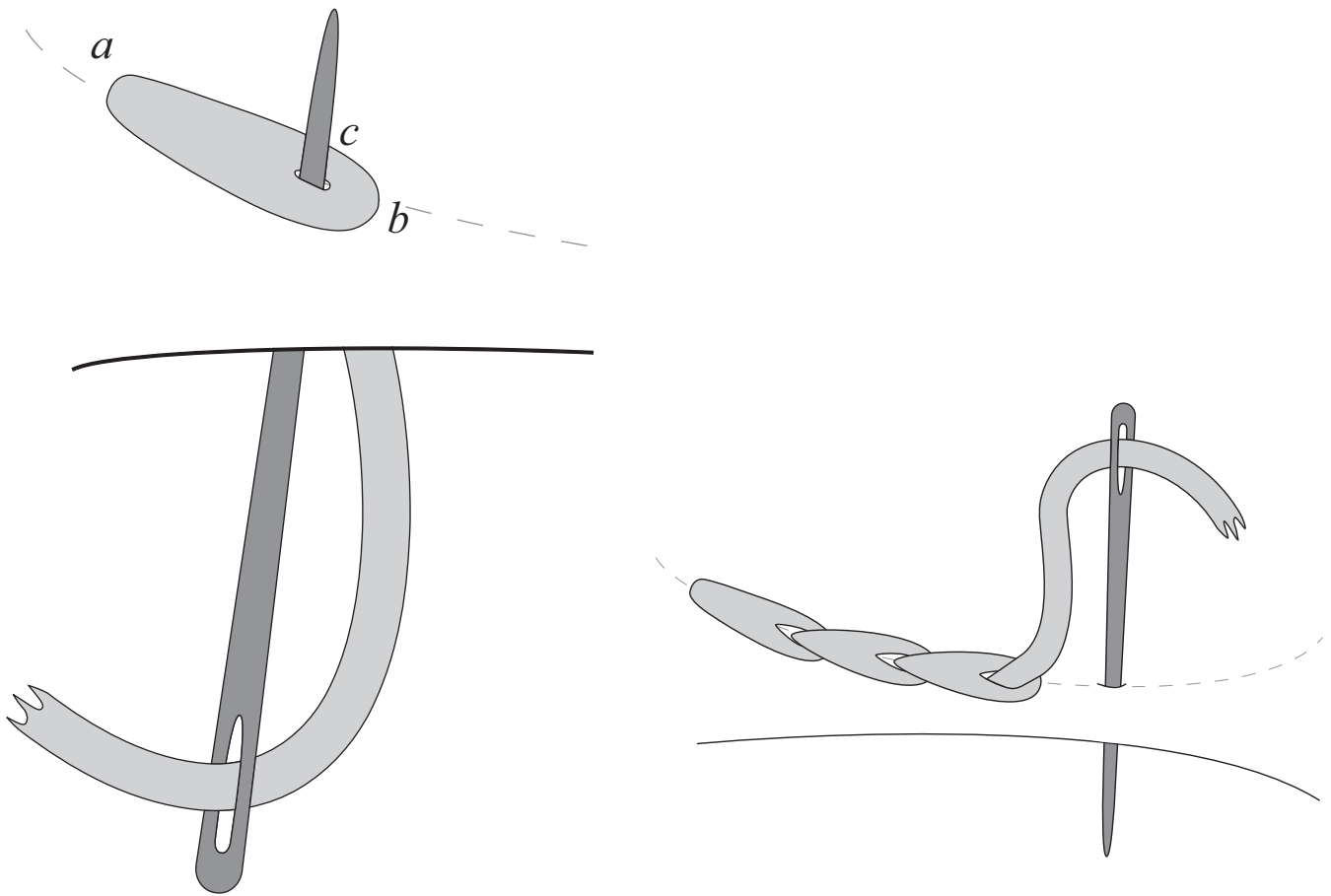

Mastering the Satin Stitch is essential. It is one of the most straight forward stitches - straight stitches parallel to one another - yet possibly the most difficult to perfect. Trying to cover too large of an area as well as not padding will result in a loose stitch. Skipping over a thread in your fabric will result in crooked stitches. Using multiple strands looks messy.

Here are a few rules to live by:

1) **Use only 1 strand of floss at a time.** It will take longer to cover the area, but will result in the smooth texture and sheen that give the stitch its name

2) **Use a split stitch fill as padding.** Many diagrams show seed stitches or zig zag stitches as padding, but a 1 strand split stitch gives the support and friction necessary to ensure that no stitch comes out of place.

*Padded Satin Stitch
(over Split Stitch padding)*

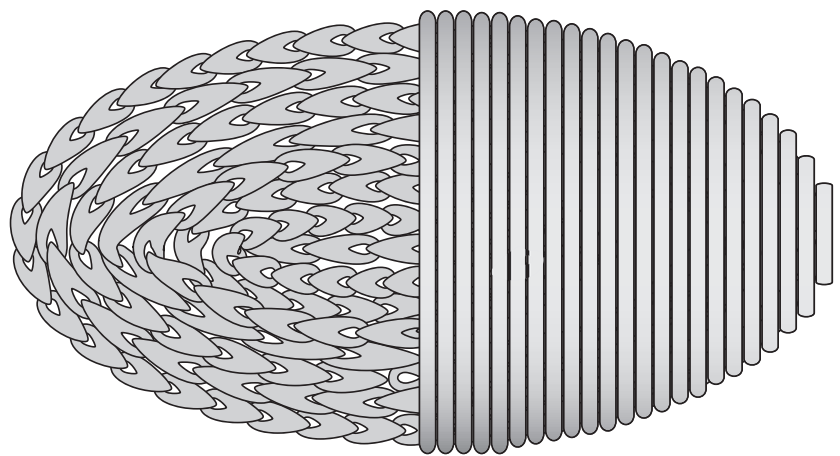

3) **Use the fabric's woven texture as your guide.** Move through the fabric one thread at a time - this will keep the stitches perfectly parallel.

The satin stitch requires patience, finesse, and an observant eye, but once you perfect this stitch the quality look of your embroideries will increase exponentially.

I only recommend an unpadding satin stitch if you are covering a very small area with no room for padding.

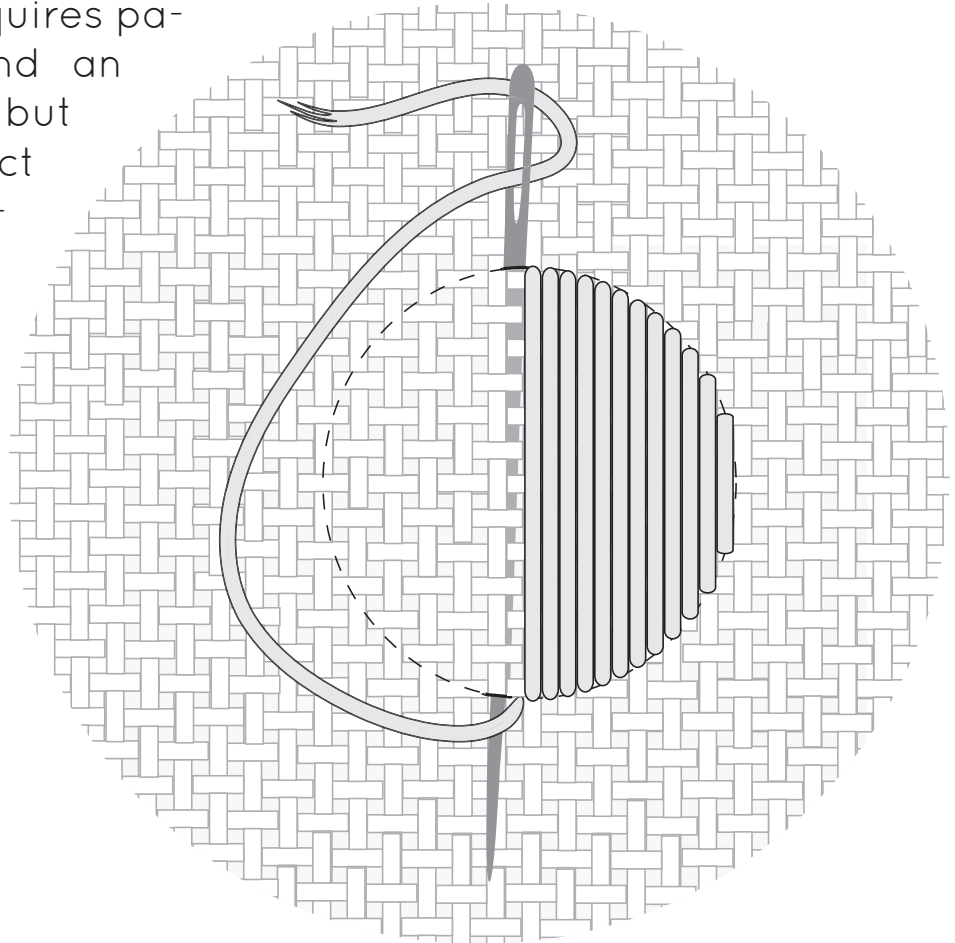

French Knot • 20

Bring the thread out where you want to place your knot. With your left thumb and index finger pull the thread firmly to the left. Wrap the thread around the needle twice, and angle the needle close to where the thread first emerged (but not in the exact place or it will pull through) slightly piercing through the fabric. Give the thread a tug, tightening up the coil. Slide the coil down towards the fabric and, keeping the tension, pull the needle through to the back, leaving a small knot on the surface. You can make single knots or clusters of knots by placing them close together.

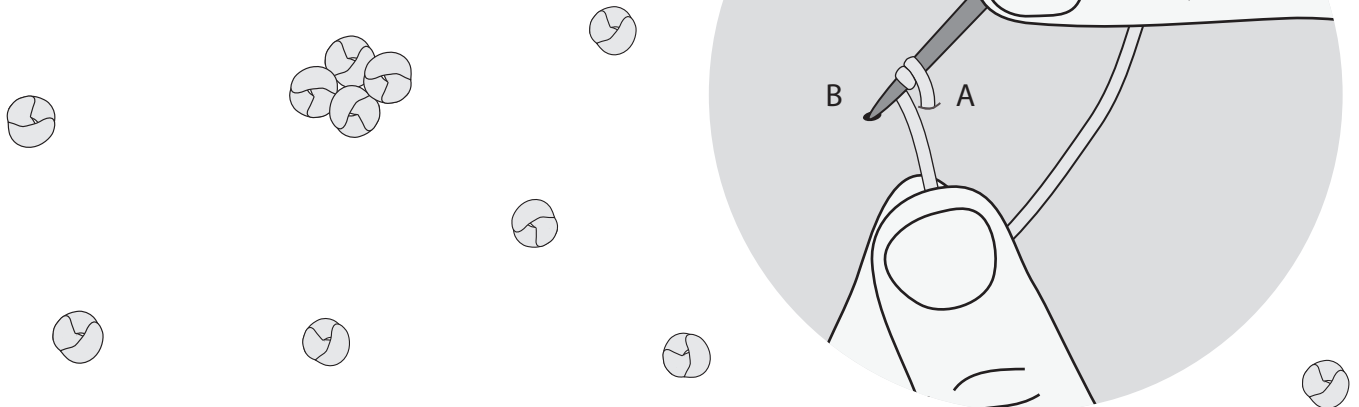
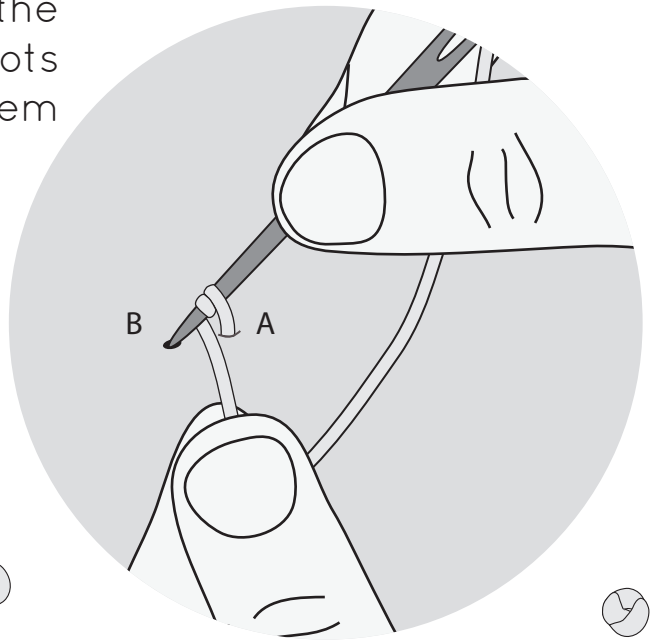
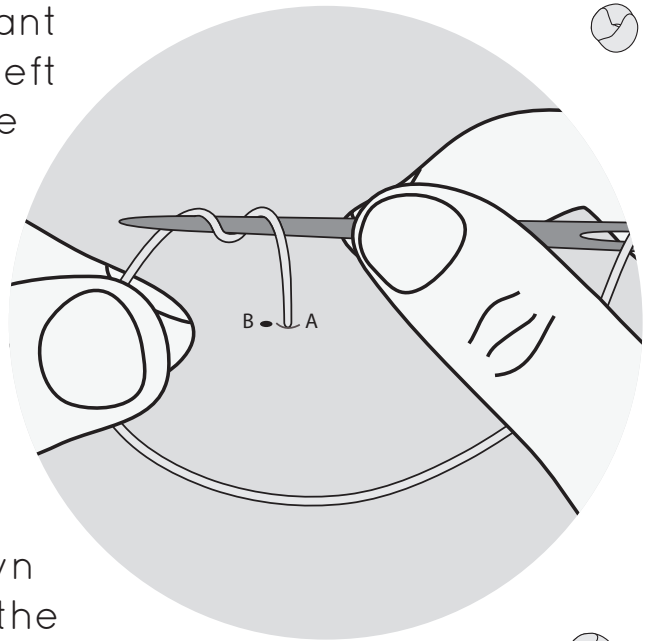

Arrowhead Stitch • 21

The Arrowhead Stitch is a simple stitch resembling a “V”. To begin, make a straight stitch from (a) to (b). Come out through (c) and re-insert your needle at (b). A horizontal row of Arrowhead Stitches created a zig-zag pattern. Stack stitches close together vertically for a Closed Arrowhead Stitch

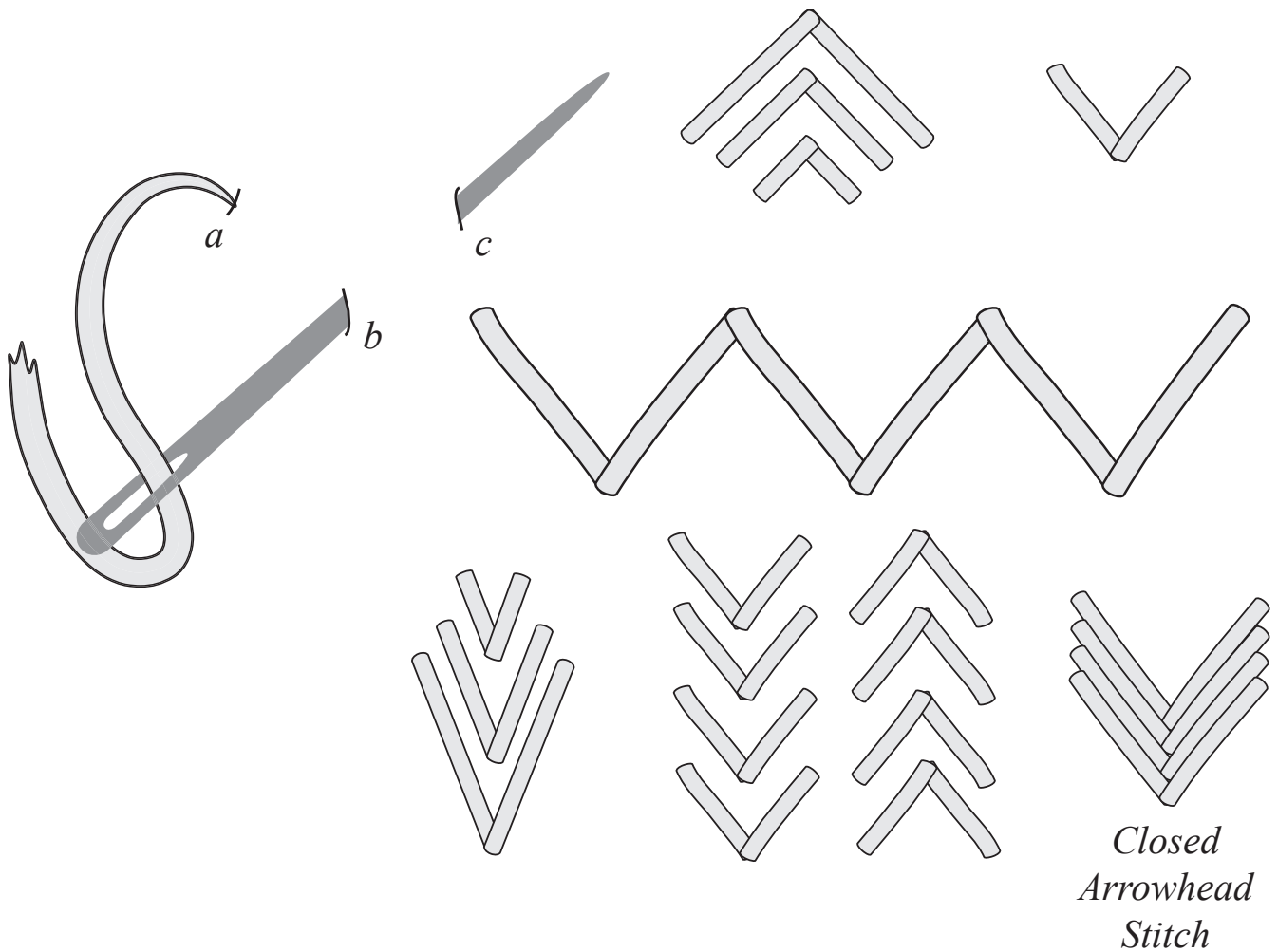

Square Laid Work • 22

Laid work is a very simple way to fill any shape using Straight Stitches. Begin by filling your shape with vertical or horizontal lines (A). Make a row of perpendicular stitches (B). In a uniform direction, make small diagonal stitches (Cross Stitches) where the two sets of Straight Stitches intersect (C). You can leave it as is, or make another series of diagonal stitches in the opposite direction to make a “x” (D).

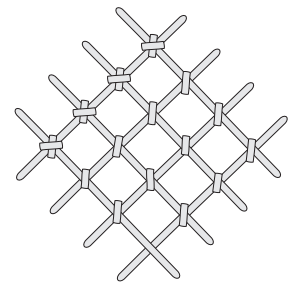
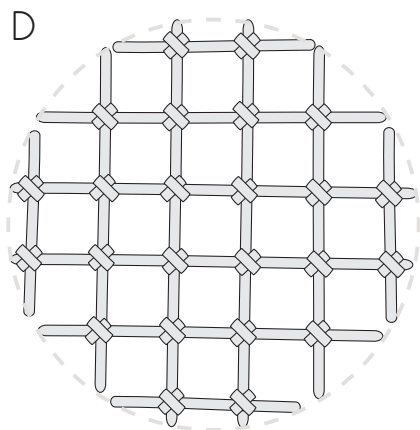
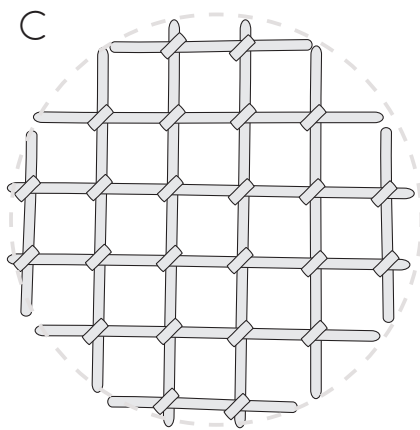
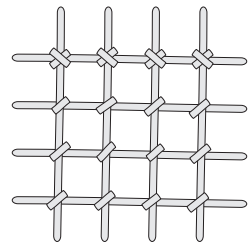
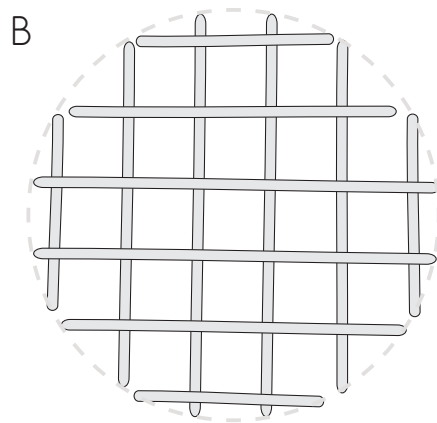
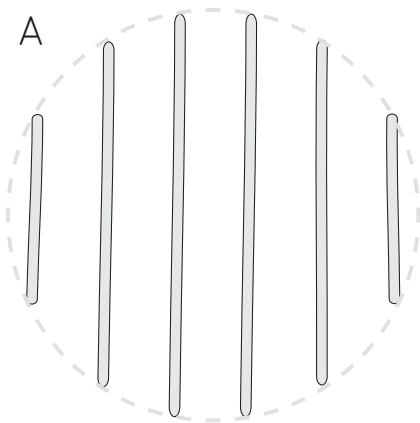

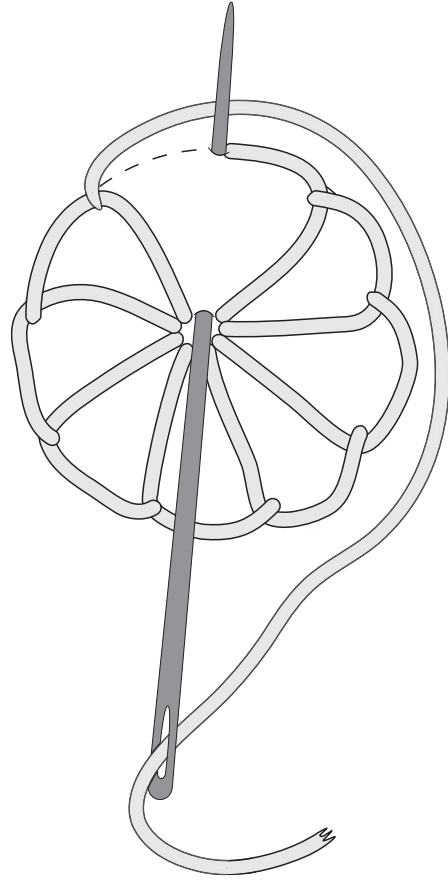

kirikí

www.kirikipress.com